

SQUARE FOOTAGE CALCULATIONS

305 Kincaid Place, Mill Spring

Approximate Total Finished/Heated Living Area:
5630 Square Feet

First Floor: 3105 Square Feet
Below Grade: 2525 Square Feet

Additional Non-Contiguous Heated Living Areas:
1030 Square Feet

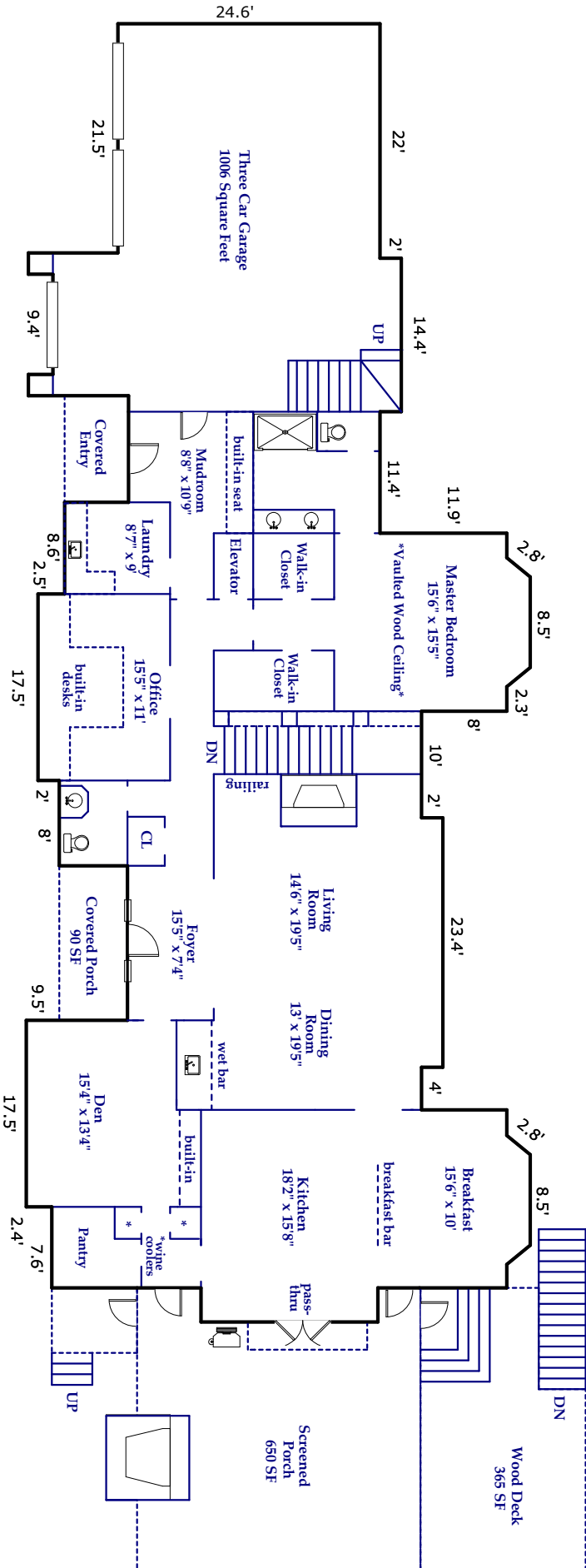

FIRST FLOOR 3105 Square Feet

Prepared by Agent Services: Beverly-Hanks & Associates
Information herein deemed reliable, but not guaranteed. Floor plan for review purposes only. All dimensions approximate. Not for construction.

SQUARE FOOTAGE CALCULATIONS

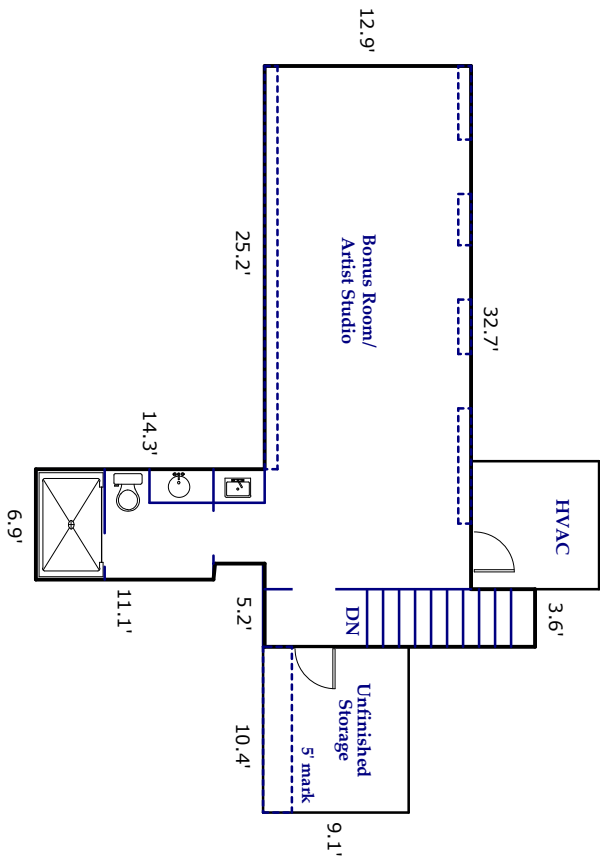

BONUS AREA ABOVE GARAGE 525 Square Feet

Non-Contiguous Heated/Finished Area